

# OPTICO 1x16 ABS PM PLC Splitter Datasheet

Widely used in fiber Sensing system/Fiber Sensor/Fiber Laser/Test Bed.



## • Description

Polarization Maintaining Planar Light wave Circuit (PLC) splitter is a type of polarization maintaining optical power management device that is fabricated using silica optical waveguide technology. PM PLC splitter maintains polarization of input optical signal. Polarization Maintaining Fiber Splitter is an optical splitter in which the polarization of linearly polarized light waves launched into the fiber is maintained during propagation, with little or no cross-coupling of optical power between the polarization modes.

## • Advantages

- Low insertion loss and high return loss
- Wide Band and Operating Temperature
- High polarization extinction ratio
- Good Splitting Uniformity
- Low insertion loss
- The length of pigtail: 1.0m as default(also customized)
- The Axis: Slow Axis as default, Fast Axis is also available
- High-low temperature cycle test
- 100% tested before delivery

## • Transmission Drawing(Unit: mm)

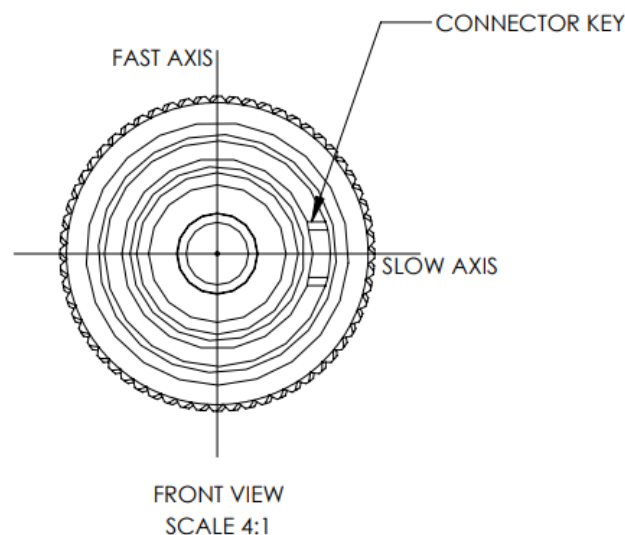

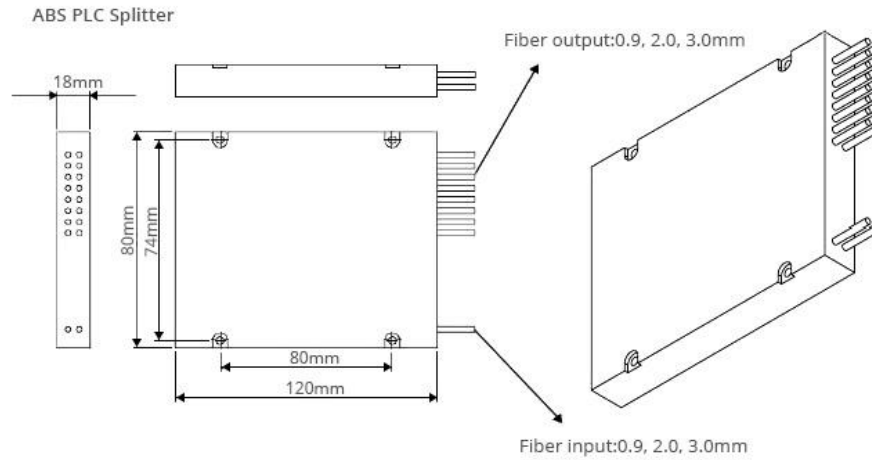

• Specifications:

| Item                            | 1x16 ABS PM PLC Splitter |
|---------------------------------|--------------------------|
| Operating wavelength(nm)        | 420~456                  |
| Fiber Type                      | Slow axis PM Panda Fiber |
| Insertion loss(dB)              | ≤13.7                    |
| Loss Uniformity(dB)             | 1.2                      |
| Polarization Dependent Loss(dB) | 0.2                      |
| Return loss(dB)                 | ≥50                      |
| Directivity(dB)                 | ≥55                      |
| PER                             | ≥18                      |
| Operating Temperature(°C)       | -40~+85                  |
| Storage Temperature(°C)         | -40~+85                  |
| Fiber Length(m)                 | As custom requested      |
| Connector Type                  | As requested             |
| Dimensions(LxWxH)               | 10x80x100m               |

Note:

1. Specified without connectors
2. Add an additional 0.2dB loss including connectors

Tips:

Due to the COVID-19, sorry that you and our team couldn't visit face to face with each other. In order to make the customers know us more, please visit our VR factory, it is just like you were really standing in our factory.

OPTICO fiber assemblies: <https://www.linked-reality.com/company/15555/en>